

Datasheet ESRF-ESF

Resistive MEMS Gas Flow Sensor

- State of the art performance due to MEMS resistive technology
- High accuracy and resolution
- $<\pm 1.25\%$ RD Total Error Band
- Wide dynamic range
- Bidirectional Flow Measurement
- Gas Flow sensor: up to ± 300 l/min
- Temperature compensation: 0°C to $+50^{\circ}\text{C}$
- Calibrated & temperature compensated analog or digital output
- Excellent long term stability
- Low temperature drift
- Compact size



Product Summary

ES Systems has developed ESRF-ESF, an inline gas flow sensor, based on the hot-film anemometer principle for mass gas flow measurements.

ESRF-ESF is one of the few gas flow sensors featuring bidirectional gas flow sensing of up to ± 300 l/min with a total error band of $<\pm 1.25\%$ RD. ESRF-ESF gas flow sensors provide calibrated and temperature compensated output on an SPI, I²C bus or analog output making them plug & play for direct interfacing to low voltage MCUs and systems. The user is provided with a multitude of interface and output options so that the right sensor configuration can be selected based on the specific requirements for each application.

Calibration gas is air but other non-aggressive gases are available upon request.

Typical Applications

Medical

Ventilation • Anesthesia • Inspiratory flow sensing • Gas mixing • Respiratory measurements • Drug delivery • Expiratory flow measurement • Metabolic Measurements • Proximal Flow measurement • Proximal flow measurement for infants / neonates • Expiratory flow measurement for infants / neonates • Ventilation & Anesthesia for infants / neonates • Respiratory measurements for infants / neonates • Metabolic Measurements for infants / neonates • Oxygen concentrators and conservers • Respirators and ventilators • Nebulizers • Continuous positive airway pressure (CPAP) • Anesthesia machines • Anesthesia delivery machines, ventilators • ventricular assist devices (heart pumps), spirometers • laparoscopy

Industrial

Mass flow controllers (Telecommunication systems, Environmental climate controls, Fuel cell controls, Process gas control welding equipment and lasers) • Analytic instrumentation (spectrometry, chromatography) • Air-to-fuel ratio • Fuel cells • Fume hoods • Gas leak detection • Process control gas monitoring • Vacuum pump monitoring • Clogging detection • Flow measurement • Air volume measurement • Process automation • Burner control • Environment monitoring • Laboratory

1. Total Error Band

Total Error Band (TEB) is a single specification that includes all possible sources of error in a gas flow measurement. TEB should not be confused with accuracy, which is actually a component of TEB. TEB is the worst error that the sensor could experience. The TEB specification on a datasheet may be confusing. ES Systems uses the TEB specification in its datasheet because it is the most comprehensive measurement of a sensor's true accuracy. ES Systems also provides the accuracy specification in order to provide a common comparison with competitors' literature that does not use the TEB specification.

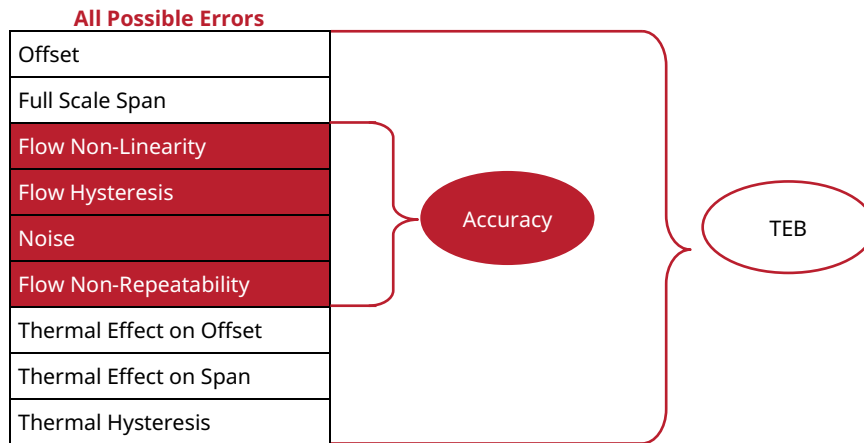

The figure below, illustrates the accuracy as well as the total error of the flow measurement of ESRF-ESF sensors.

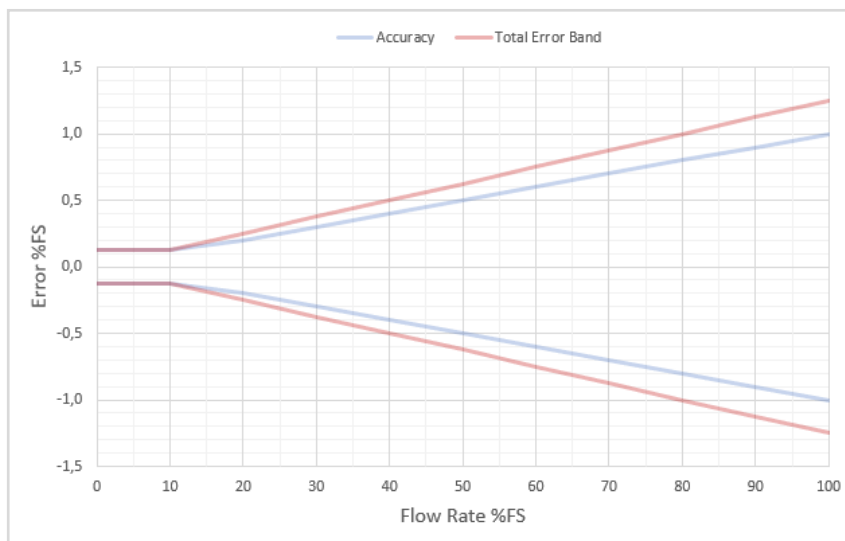

Accuracy Performance

Range: 15, 20, 50, 100, 200, 300 l/min
 - 0% FS to 10%FS = $\pm 0.125\%FS$
 - 10%FS to 100%FS = $\pm 1.0\% RD$

Total Error Band Performance

Range: 15, 20, 50, 100, 200, 300 l/min
 - 0% FS to 10%FS = $\pm 0.125\%FS$
 - 10%FS to 100%FS = $\pm 1.25\% RD$

2. Absolute Maximum Ratings¹

Characteristic	Min.	Max.	Unit
Supply voltage (V_{supply})	4.8	5.5	Vdc
Voltage on any pin	-0.3	5.5	V
Current on any pin	-	2	mA
Burst pressure	-	2	barg
Storage temperature	-20[-4]	+85[+185]	°C[°F]
Maximum flow applied	-550	550	l/min

¹ Absolute maximum ratings are the extreme limits the device will withstand without damage. The electrical and performance characteristics are not guaranteed as the maximum limits are approached, nor will the device necessarily operate as specified at absolute maximum ratings. Prolonged operation at absolute maximum ratings will degrade the device performance

CAUTION

IMPROPER USE

Do not use these products to sense liquid flow.
Failure to comply with the instructions may result in product damage.

CAUTION

PRODUCT DAMAGE

Do not disassemble these products.
Failure to comply with the instructions may result in product damage.

3. Operating Specifications

Characteristic	Min.	Typ.	Max.	Unit
Supply voltage (V_{supply}) ¹	4.8	5.0	5.2	V
Supply current	-	-	80	mA
Output	I ² C, SPI, Analog			-
Start-up time ²	-	100	-	msec
Operating temp. range	-20[-4]	-	+85[+185]	°C[°F]
Compensated temp range	0[+32]	-	+50[+122]	°C[°F]
Relative humidity (non-condensing)	0	-	95	% RH
Pneumatic connection type	ISO5356-1:2004			-
Compatible gases	Inert non aggressive gases			-
Gas conversion factor				
Air to O ₂	-	1.0190	-	-
Air to N ₂	-	0.9997	-	-
Update rate	1.6	-	-	ms
Digital bus frequency	-	-	100	kHz
Analog output loading				
Sink	-	-	10	mA
Source	-	-	20	mA

¹The sensor is not reverse polarity protected. Incorrect application of supply voltage or ground to the wrong pin may cause electrical failure

²After 95% of V_{supply} reached

4. Flow Sensor Specifications

Characteristic	Absolute			Unit
	Min.	Typ.	Max.	
Flow direction	Unidirectional / bidirectional			-
Full scale ranges				
Unidirectional	10, 15, 20, 50, 100, 200, 300			In/min ¹
Bidirectional	±10, ±15, ±20, ±50, ±100, ±200, ±300			
Flow cut ²	1.0			%FS ³
Max measured flow	-330	-	330	In/min
Calibration gas	Clean, Dry Air ⁴			-
Operating temp. range ⁵	-20[-4]	-	+85[+185]	°C[°F]
Compensated temp range ⁶	0[+32]	-	+50[+122]	°C[°F]
Operating pressure	1.0	-	1.3	bara
Proof pressure	-	-	1.7	bara
Effective resolution	12	-	-	bits
Response time	-	35	-	msec
Total error band ^{7,8} (<10%FS)	-	±0.125	-	%FS
Total error band ⁷ (>10%FS)	-	±1.25	-	%RD ⁹
Accuracy ^{10,11} (<10%FS)	-	±0.125	-	%FS
Accuracy ¹⁰ (>10%FS)	-	±1.0	-	%RD
Orientation sensitivity ¹²	-	0.001	-	%FS/°
Long term stability ¹³	-	-	±0.1	%FSS ¹⁴

¹ In normal liters per minute at 0°C and 1013 mbar

² Flow measured below this point will always indicate 0 In/min

³ % of the full scale

⁴ Other, non-aggressive, gases available upon request

⁵ The temperature range over which the sensor will produce an output proportional to flow (Non condensing humidity)

⁶ The temperature range over which the sensor will produce an output proportional to flow within the specified performance limits. Note that for valid datasheet values, ambient and gas temperatures must be the same

⁷ The maximum deviation from ideal transfer function over the entire compensated temperature and flow range. Includes all errors due to offset, full scale span, accuracy, thermal effect on offset, thermal effect on span and thermal hysteresis

⁸ For the 10 In/min FS flow option only, TEB for flows <10%FS is ±0.5%FS

⁹ % of the reading value

¹⁰ The maximum deviation in output from a Best Fit Straight Line (BFSL) fitted to the output measured over the flow range at 21°C [69.8°F]. Includes all errors due to flow non-linearity, flow hysteresis, non-repeatability and noise

¹¹ For the 10 In/min FS flow option only, accuracy for flows <10%FS is ±0.5%FS

¹² Added measurement error due to orientation deviation from the optimal (calibration) position

¹³ Accelerated Life Test Profile: 100hours at 90°C

¹⁴ Full Scale Span (FSS): The algebraic difference between the output signal measured at the maximum (U_{max}) and the minimum (U_{min}) limits of the flow range

5. Flow Range Specifications (ln/min)

Flow Range	Flow Range			Unit	Pressure Drop @ FS	Unit
	U _{min} ¹	U _{max} (Digital Output) ²	U _{max} (Analog Output)			
010NL	0.1	11	10	ln/min	0.07	mbar
015NL	0.15	16.5	15	ln/min	0.15	mbar
020NL	0.2	22	20	ln/min	0.17	mbar
050NL	0.5	55	50	ln/min	1	mbar
100NL	1	110	100	ln/min	2.4	mbar
200NL	2	220	200	ln/min	8.6	mbar
300NL	3	330	300	ln/min	18.4	mbar

¹ Flows below U_{min} will always indicate 0 ln/min

² In order to improve the quality of the flow measurements, the digital output features an extra 10% flow range from the nominal FS flow.

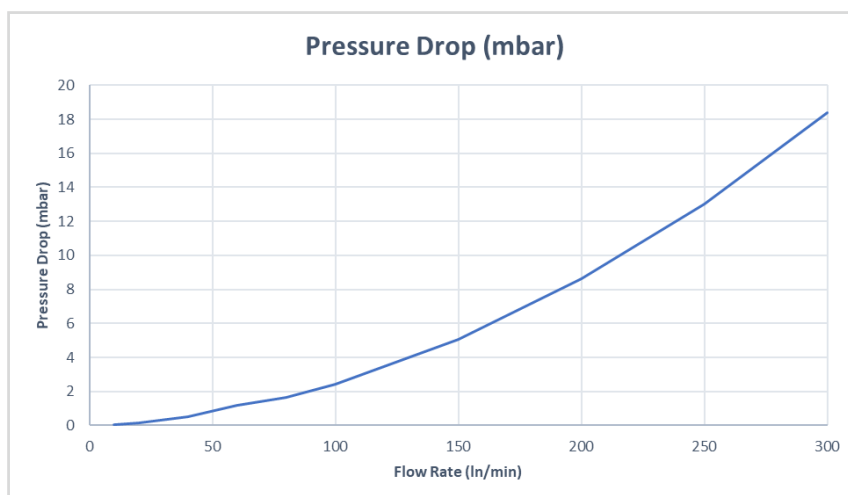

6. Temperature Sensor Specifications

Characteristic	Absolute			Unit
	Min.	Typ.	Max.	
Full Scale range	0 [+32]	-	+50 [+122]	°C[°F]
Accuracy	-	0.5	-	°C
Resolution	8	-	-	bits

7. Data & Register Description

The ESRF-ESF sensors provide measurement and status data. The measurement data are **flow rate** and **temperature** whilst the status data refer to the sensors factory programmed **serial number**. The data are stored in specific data registers as described below. The readout is performed by using multibyte read transactions.

Flow Data Register [0x00]

ADDRESS	REGISTER NAME	TYPE	DEFAULT VALUE (Hex)	MNEMONIC
0x00	Calibrated Flow Byte 1	R	Variable	CAL_DATA[15:8]
	Calibrated Flow Byte 2	R	Variable	CAL_DATA[7:0]

When performing transaction with the ESRF-ESF sensors the returned data is always MSB first. Flow is represented as a 16-bit, two's complement number. The lowest number in the Flow Data Register is 0x8000 (-32768 in Decimal) and the highest number is 0x7FFF (32767 in Decimal). In unidirectional ESF sensors output data higher than 0x7FFF must be ignored.

Calibrated flow (in SLPM) can be calculated using the following formula:

$$Flow\ Rate = \left(\frac{CAL_DATA[15:0]}{32768} \times Full\ Scale\ Flow \right) \times 1.1 \quad Eq. 1$$

An example of **unidirectional** flow:

Flow Register Byte [0] = 0x3F

Flow Register Byte [1] = 0xFF

Using the formula (Eq 1) and assuming a full scale flow of 200 l/min, the calculated output should be 109.9932 l/min

An example of **bidirectional** flow:

Flow Register Byte [0] = 0xFC

Flow Register Byte [1] = 0x18

Using the formula (Eq.1) and assuming a full scale flow of 200 l/min, the calculated output should be -6.7139 l/min

Temperature Data Register [0x01]

ADDRESS	REGISTER NAME	TYPE	DEFAULT VALUE	MNEMONIC
0x01	Calibrated Temp Byte 1	R	Variable	CAL_DATA[15:8]
	Calibrated Temp Byte 2	R	Variable	CAL_DATA[7:0]

Temperature is represented as a 16-bit, unsigned integer number. The lowest number in the Temperature Data Register is 0x0000 (0 in Decimal) and the highest number is 0xFFFF (65535 in Decimal). The full data representation range of this register in °C is from -20°C to +80°C. However, the temperature sensor accuracy is defined within the temperature compensation range of the device which is from 0°C to +50°C .

Calibrated Temperature (in °C) can be calculated using the following formula:

$$Temperature = \left(\frac{CAL_DATA[15:0]}{65535} \times 100 \right) - 20 \quad \text{Eq. 2}$$

An example of **Temperature** conversion:

Temperature Register Byte [0] = 0x84

Temperature Register Byte [1] = 0x32

Using the formula (Eq. 2) the calculated output should be 31.64°C

Serial Number Register [0x03]

ADDRESS	REGISTER NAME	TYPE	DEFAULT VALUE (Hex)	MNEMONIC
0x03	Serial Number Byte 1	R	Fixed ID	SER_NO[31:24]
	Serial Number Byte 2	R	Fixed ID	SER_NO[23:16]
	Serial Number Byte 3	R	Fixed ID	SER_NO[15:8]
	Serial Number Byte 4	R	Fixed ID	SER_NO[7:0]

Each ESRF-ESF sensor is uniquely identified by a 32-bit serial number. This number can be read from the Serial Number Register and is 4 bytes long.

An example of a **serial number** conversion:

Serial No Register Byte [0] = 0x01

Serial No Register Byte [1] = 0x05

Serial No Register Byte [2] = 0x62

Serial No Register Byte [3] = 0x1F

The serial number 0x0105621F corresponds to 17130015 in decimal.

Software Reset Function [0xFE]

The device has an additional option to perform a software reset via the I2C communication interface. This option is useful in specific cases depending on the application. For instance, the user could issue a S/W reset to assure correct initialization after a hot-plug connection.

The procedure to reset the device is the same as changing a register, followed by the byte 0xFE. In other words, the user must first send the byte 0x8A (7 bit address plus write bit) and then the byte 0xFE (I²C Mode) or just 0xFE (SPI Mode). The device will then return its acknowledge bit and immediately reset itself. After 100 milliseconds, the device will be ready to give its first valid sample.

8. I²C Interface

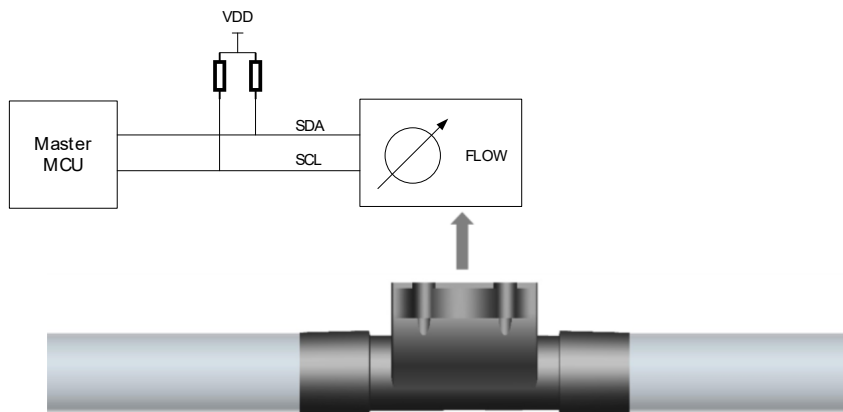

At power on reset, the sensor defaults to transmission of the contents of the Flow Data Register. If the master device transmits the selected sensor 7-bit address (**0x45**) with R/W bit set, the sensor returns the contents of the Flow Data Register after acknowledging (ACK) by holding the SDA line low. The master should then provide at least 18 clock pulses on the SCL line in order to readout the two Flow Data Bytes. An acknowledge bit (ACK) should be provided by the master on each byte received by holding the SDA line low while providing the 9th clock pulse. The same frame structure also applies to a Temperature Data transaction. An example of such a transaction can be seen below.

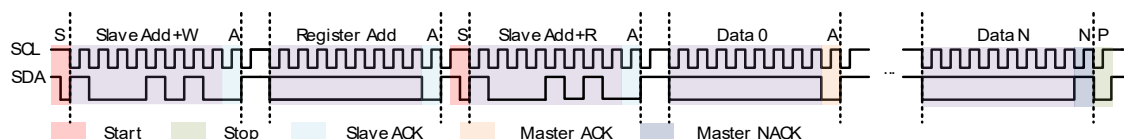

If in any case the master sends a slave address or a register address that is not recognized a NACK condition will be returned by the sensor. The sensor supports clock stretching functionality

9. SPI Interface

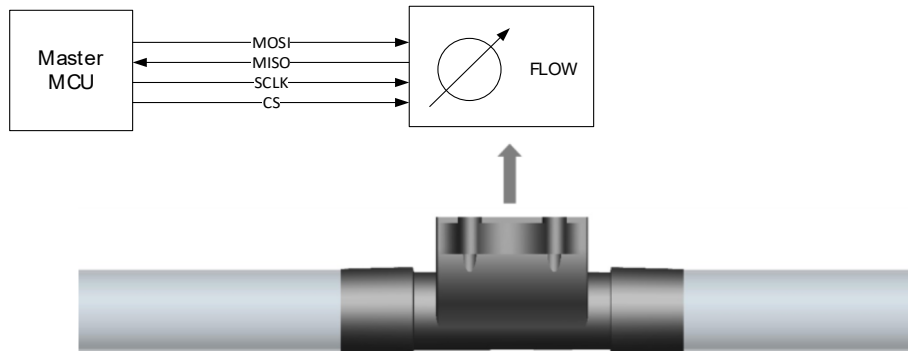

ESRF-ESF sensors have the option of a serial peripheral interface communication following the memory mapping as described in section 9. The sensor uses MODE 0 SPI with CPOL = 0 and CPHA = 0.

The SPI communication requires to send, via the MOSI signal, the address to read and then the following clock pulses will produce the required result on the MISO line. The following examples describe the SPI transactions for reading the flow and the temperature output of the sensor.

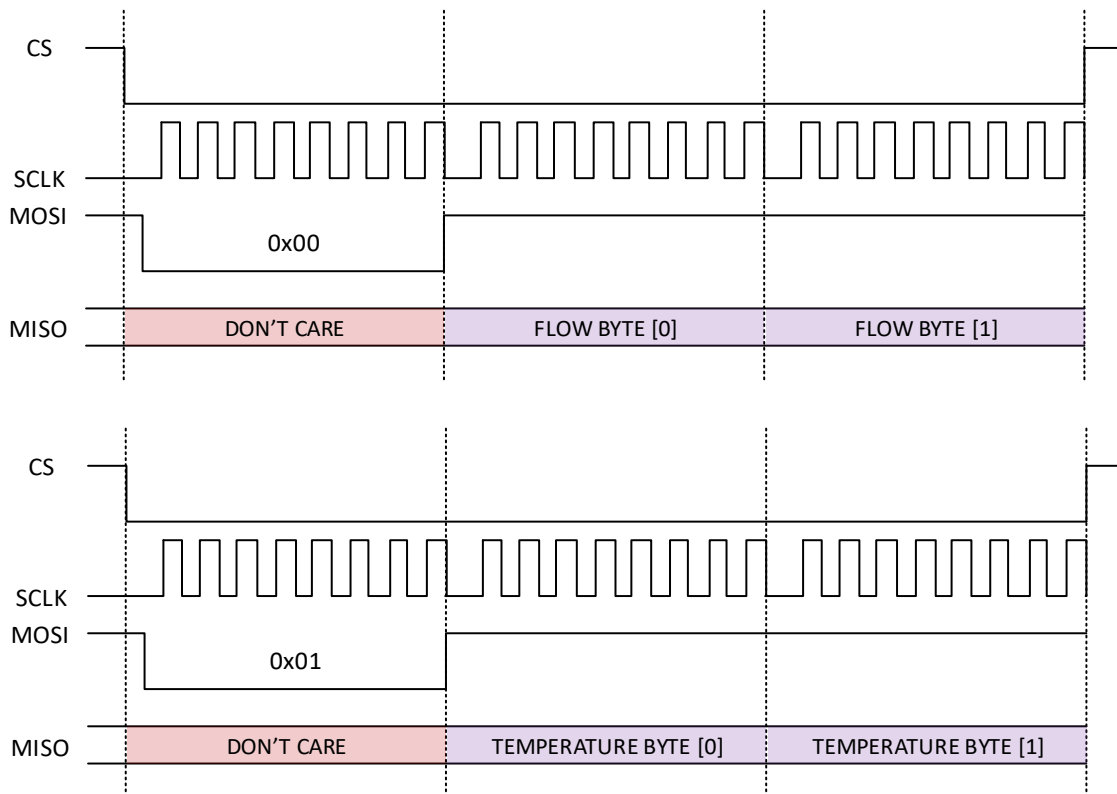

10. Analog Interface

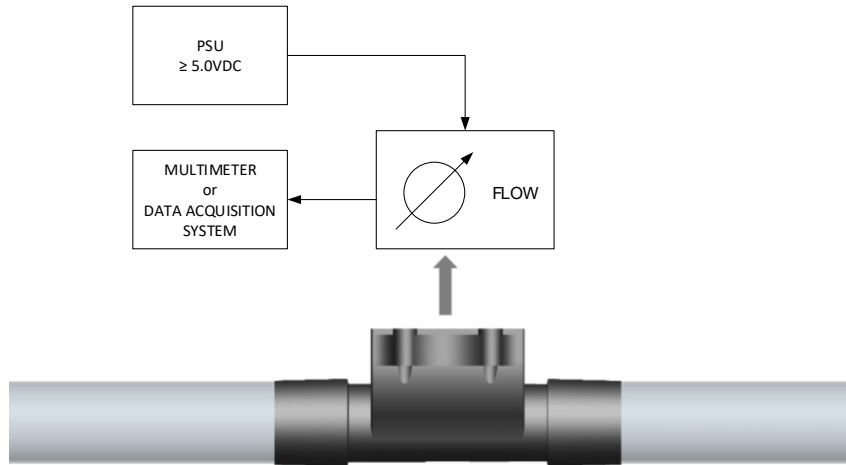

ESRF-ESF sensors also feature the option of an analog voltage output (+0.5 to +4.5V), which allows for the readout of flow in an analog way by means of a data acquisition system or a multimeter. In this case the user needs to ensure that the power supply can sustain the power requirements of the sensor at full flow as specified in the electrical specifications table. As this is a voltage output configuration the user must ensure that the cables running from the sensor to the data acquisition system are as short as possible to prevent errors from potential voltage drops. It should be noted that the min analog voltage output is 0.5V and the maximum 4.5V

$$\text{Unidirectional Flow Rate} = \frac{\text{Measured Voltage (V)} - 0.5V}{4.0V} \times \text{Full Scale Flow} \quad \text{Eq. 3}$$

$$\text{Bidirectional Flow Rate} = \left(\frac{\text{Measured Voltage (V)} - 0.5V}{4.0V} \times 2\text{Full Scale Flow} \right) - \text{Full Scale Flow} \quad \text{Eq. 4}$$

17. Wetted Materials¹

Component	Flow Port
Ports and covers	Glass Reinforced Thermoplastic, Gold, Si, SiN, SiO _x , epoxy, silicon rubber, FR4, polyurethane, SS316, Fluoropolymer
Housing	Glass Reinforced thermoplastic
Substrate	Gold, FR4
Adhesives	Epoxy
Weight	50.6g
Directives compliance	RoHS, WEEE, CE

¹ Contact ES Systems Customer Service for detailed material information

11. Pinout

Output ¹	PIN1	PIN2	PIN3	PIN4	PIN5	PIN6
I ² C	NC	NC	VCC	GND	SDA	SCL
SPI	CS	MISO	VCC	GND	MOSI	SCLK
Analog	Output +	Output - ²	VCC	GND	NC	NC

¹ Connector P/N: S6B-PH-K-S, manufacturer: JST

² Analog ground

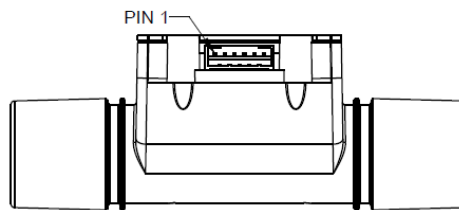

12. Environmental Specifications

Characteristic	Parameter
Wetted materials degree of protection	IEC IP40 (excluding tubing sections)
Vibration	15g, 10Hz to 2 kHz
Shock	100g, 6ms duration
ESD	ESD IEC6100-4-2 air discharge up to 8 kV, or direct contact discharge up to 4 kV
EMC/EMI	level 3 from 80 MHz to 1000 MHz per IEC61000-4-3, 1m shielded cable with 3cm exposed leads at connector.
Life ¹	1 million flow cycles minimum

¹ Life may vary depending on specific application in which the sensor is used

15. Mechanical Specifications (all dimensions in mm)

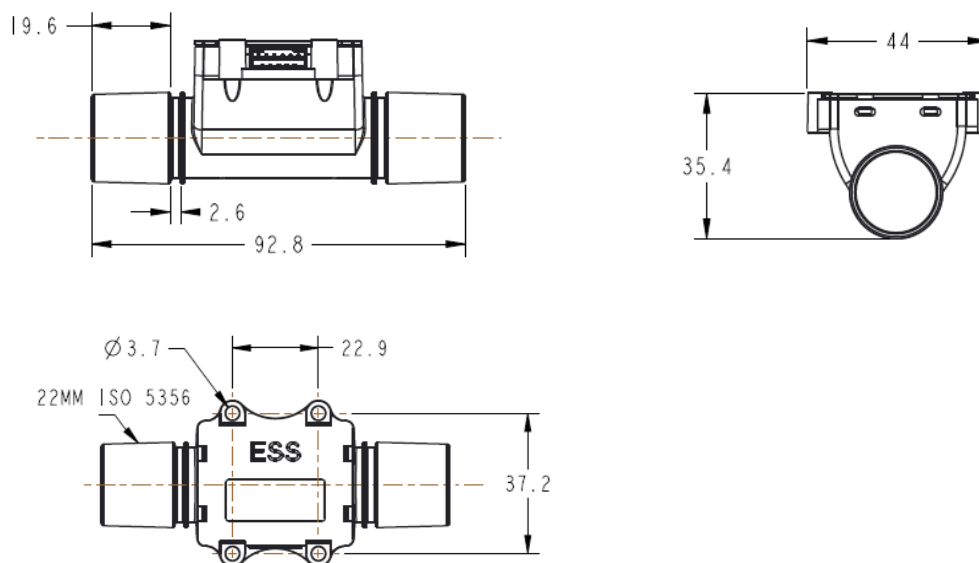

13. Instructions of Use

Calibration orientation

The ESRF-ESF sensors are calibrated in a horizontal position. As depicted in the following graph.

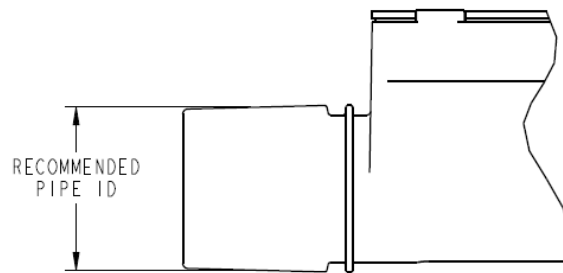

For optimal performance, the sensor requires at least 20x ID of laminarizing pipe length in the flow inlet and another 20x ID in the outlet. ESRF-ESF sensors are calibrated using 20mm ID pipe diameter. The diameter of the inlet and outlet flow pipes should be as close to the calibration diameter as possible. It is also possible to insert O-rings in the grooves and attach tubes with an inner diameter of 23 mm to the ESRF-ESF. The dimensions of the O-ring are illustrated bellow.

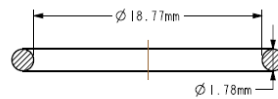

Temperature compensation

The ESRF-ESF sensor features digital temperature compensation. The temperature is measured on the MEMS element by an on-chip temperature sensor. This data is fed to a compensation circuit that is also integrated on the microprocessor. Thus, no external temperature compensation is necessary.

Sensor Handling

The ESRF-ESF sensor is designed to be robust and shock resistant. Nevertheless, the accuracy of the high-precision ESRF-ESF can be degraded by rough handling. ES Systems does not guarantee proper operation in case of improper handling.

14. Ordering Information

ESRF-ESF-NNNNN-NN-NN-NN-N

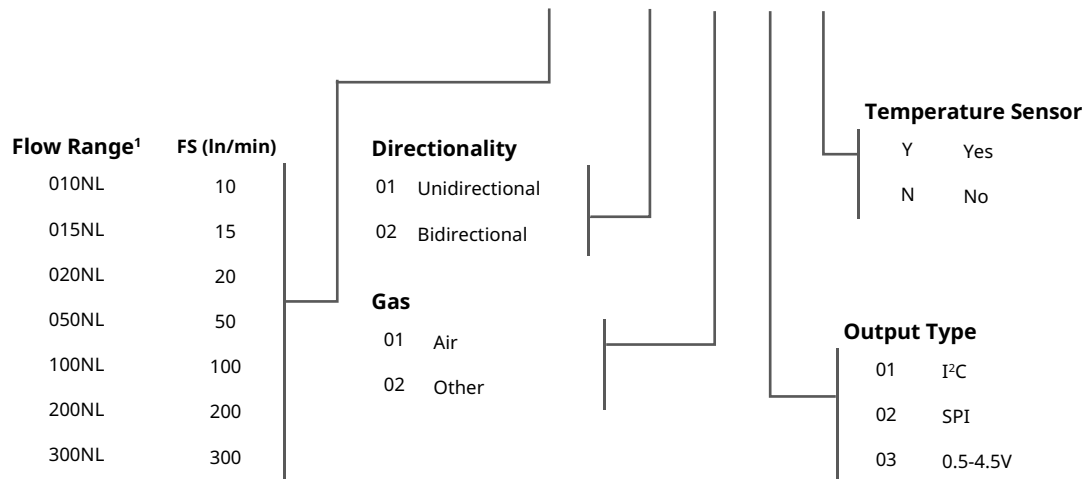

¹Custom calibration ranges are available upon request

Important Notes

PERSONAL INJURY

DO NOT USE these products as safety or emergency stop devices, or in any other application where failure of the product could result in personal injury.

Failure to comply with these instructions could result in death or serious injury.

WARRANTY

ES Systems warrants this Product to be free of defects in materials and workmanship for a period of one (1) year from the date of purchase.

Upon examination by ES Systems, if the unit is found to be defective it will be repaired or replaced at no charge. ES Systems' WARRANTY does not apply to defects resulting from any action of the purchaser, including but not limited to mishandling, improper interfacing, operation outside of design limits, improper repair, or unauthorized modification. This WARRANTY is VOID if the unit shows evidence of having been tampered with or shows evidence of being damaged as a result of excessive corrosion; or current, heat, moisture or vibration; improper specification; misapplication; misuse or other operating conditions outside of ES Systems' control. Components which wear are not warranted.

ES Systems neither assumes responsibility for any omissions or errors nor assumes liability for any damages that result from the use of its Product in accordance with information provided by ES Systems, either verbal or written. ES Systems warrants only that the parts manufactured by it will be as specified and free of defects.

ES SYSTEMS MAKES NO OTHER WARRANTIES OR REPRESENTATIONS OF ANY KIND WHATSOEVER, EXPRESSED OR IMPLIED, EXCEPT THAT OF TITLE, AND ALL IMPLIED WARRANTIES INCLUDING ANY WARRANTY OF MERCHANTABILITY AND FITNESS FOR A PARTICULAR PURPOSE ARE HEREBY DISCLAIMED.

No representative of ES Systems is authorized to extend this Warranty or to change it in any manner whatsoever.

No warranty applies to any party other than the original Customer. The remedies of the Customer set forth herein are exclusive and the total liability of ES Systems with respect to this order, whether based on contract, warranty, negligence, indemnification, strict liability or otherwise, shall not exceed the purchase price of the component upon which liability is based.

In no event shall ES Systems be liable for consequential, incidental or special damages.

Specifications may change without notice. The information supplied is believed to be accurate and reliable as of this issue; however, ES Systems assumes no responsibility for its use.

Contact Information

ES Systems S.A.

Head Office:

7, Stratigi St., GR-154 51
Neo Psychico, Greece
Tel: (+30) 210 672 8610,
Fax (+30) 210 672 8624

Factory:

57, I.Metaxa str., GR-194 41
Koropi, Greece
Tel: (+30) 216 2000 500,
Fax (+30) 216 2000 555